

DB58 G-DRIVE

◎ POWER RATING

Engine Speed rev/min	Type of Operation	Engine Power	
		kWm	Ps
1800	Prime Power	64	87
	Standby Power	70	95
1500	Prime Power	54	73
	Standby Power	59	80

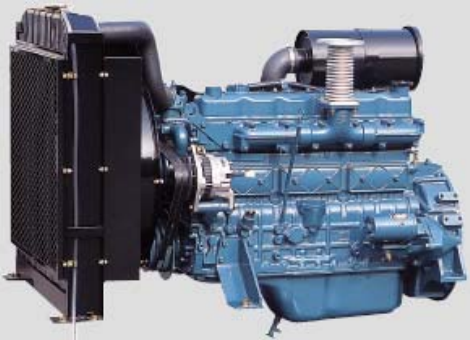

- The engine performance corresponds to ISO 3046, BS 5514 and DIN 6271.
- Ratings are based on ISO 8528. (If you need more information, contact the sales organization.)
 - **Prime power** is available for an unlimited number of hours per year in a variable load application.
The permissible average power output over 24 hours of operation shall not exceed 70% of the prime power rating.
 - **Standby power** is available in the event of a utility power outage or under test conditions for up to 200h of operation per year.
The permissible average power output over 24 hours of operation shall not exceed 70% of the standby power rating.
No overload is permitted.

◎ MECHANICAL SYSTEM

- Engine Model DB58
- Engine Type In-line 4 cycle, water cooled
Naturally aspirated
- Combustion type Direct injection
- Cylinder Type Replaceable dry liner
- Number of cylinders 6
- Bore x stroke 102(4.02) x 118(4.65) mm(in.)
- Displacement 5.785(353) lit.(in3)
- Compression ratio 17.5 : 1
- Firing order 1-5-3-6-2-4
- Injection timing 13° BTDC
- Compression pressure Above 28 kg/cm²(398 psi) at 200rpm
- Dry weight Approx. 450 kg (992 lb)
- Dimension (LxWxH) 1,155 x 705 x 854 mm
(45.5 x 27.8 x 33.6 in.)
- Rotation Counter clockwise viewed from Flywheel
- Fly wheel housing SAE NO.3
- Fly wheel Clutch NO.11 1/2

◎ MECHANISM

- Type Over head valve
- Number of valve Intake 1, exhaust 1 per cylinder
- Valve lashes at cold Intake 0.40 mm (0.0157 in.)
Exhaust 0.40 mm (0.0157 in.)

◎ VALVE TIMING

- | | Opening | Close |
|-----------------|--------------|--------------|
| ○ Intake valve | 28 deg. BTDC | 62 deg. ABDC |
| ○ Exhaust valve | 70 deg. BBDC | 28 deg. ATDC |

◎ FUEL CONSUMPTION

- | ○ Prime Power (lit/hr) | 1,500 rpm | 1,800 rpm |
|--------------------------|-----------|-----------|
| 25% | 4.8 | 5.7 |
| 50% | 7.6 | 8.4 |
| 75% | 10.5 | 12.2 |
| 100% | 13.9 | 16.4 |
| ○ Standby Power (lit/hr) | 1,500 rpm | 1,800 rpm |
| 25% | 5.9 | 6.4 |
| 50% | 8.8 | 9.8 |
| 75% | 11.7 | 13.1 |
| 100% | 15.3 | 18.1 |

◎ FUEL SYSTEM

- Injection pump Zexel in-line "A" type
- Governor RSV type (all speed control)
- Feed pump Mechanical type
- Injection nozzle Multi hole type
- Opening pressure 220 kg/cm² (3,129 psi)
- Fuel filter Full flow, cartridge type
- Used fuel Diesel fuel oil

◎ LUBRICATION SYSTEM

- Lub. Method Fully forced pressure feed type
- Oil pump Gear type driven by crankshaft
- Oil filter Full flow, cartridge type
- Oil pan capacity High level 19 liters (5.016 gal.)
Low level 16 liters (4.224 gal.)
- Angularity limit Front down 25 deg.
Front up 25 deg.
Side to side 30 deg.
- Lub. Oil Refer to Operation Manual

◎ COOLING SYSTEM

- Cooling method Fresh water forced circulation
- Water capacity 12 liters (3.17 gal.)
(engine only)
- Pressure system Max. 0.5 kg/cm² (7.11 psi)
- Water pump Centrifugal type driven by belt
- Water pump Capacity 95 liters (25.1 gal.)/min
at 1,800 rpm (engine)
- Thermostat Wax – pellet type
Opening temp. 82°C
Full open temp. 95°C
- Cooling fan Blower type, steel
520 mm diameter, 6 blade

◎ ELECTRICAL SYSTEM

- Charging generator 24V x 45A [or 12V x 26A] alternator
- Voltage regulator Built-in type IC regulator
- Starting motor 24V x 4.5kW [or 12V x 2.5kW]
- Battery Voltage 24V [or 12V]
- Battery Capacity 100 AH [or 150 AH] (recommended)
- Starting aid (Option) Block heater

◎ ENGINEERING DATA

- Water flow 77 liters/min @1,500 rpm
- Heat rejection to coolant
- Air flow 3.5 m³/min @1,500 rpm
- Exhaust gas flow
- Exhaust gas temp. 603 °C @1,500 rpm

- Water flow 95 liters/min @1,800 rpm
- Heat rejection to coolant 15.5 kcal/sec @1,800 rpm
- Air flow 4.0 m³/min @1,800 rpm
- Exhaust gas flow 8.46 m³/min @1,800 rpm
- Exhaust gas temp. 570 °C @1,800 rpm

- Max. permissible restrictions
 - .Intake system 220 mmH₂O initial
635 mmH₂O final
 - .Exhaust system 1,000 mmH₂O max.
- Max. permissible altitude 800 m

◆ CONVERSION TABLE

in. = mm x 0.0394	lb/ft = N.m x 0.737
PS = kW x 1.3596	U.S. gal = lit. x 0.264
psi = kg/cm ² x 14.2233	kW = 0.2388 kcal/s
in ³ = lit. x 61.02	lb/PS.h = g/kW.h x 0.00162
hp = PS x 0.98635	cfm = m ³ /min x 35.336
lb = kg x 2.20462	

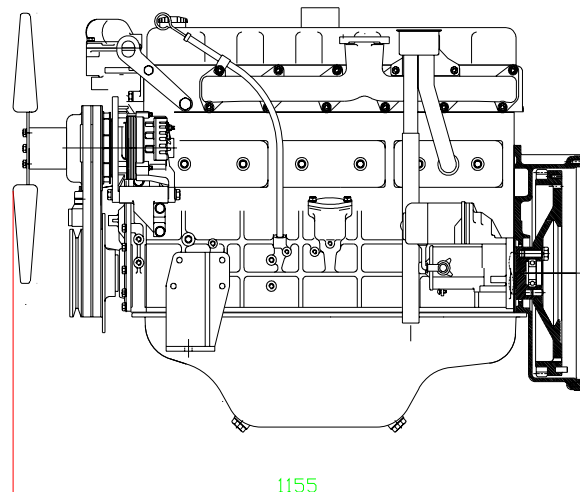
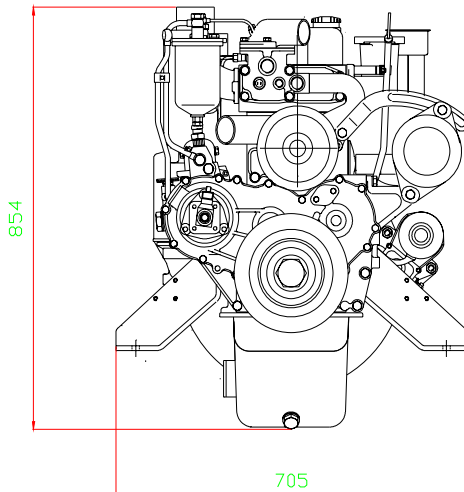

Head office

7-11, Hwasu-Dong, Dong-Gu, Incheon, Korea
TEL : 82-32-211-2246, 2222 FAX : 82-32-761-2759

Seoul Office

Doosan Infracore Co. Ltd.,
 22nd Floor, Doosan Tower, 18-12, Euljiro 6-ga, Jung-gu,
 Seoul, Korea.

TEL : 82-2-3398-8521~8535 FAX : 82-2-3398-8509

Web site : www.doosaninfracore.com

※ Specifications are subject to change without prior notice